



2010 FARWEST SHOW RULES AND REGULATIONS

FARWEST SHOW STATEMENT OF INTENT

The Farwest Show strives to provide each exhibitor with a qualified buying audience and a positive exhibition experience. A full-time professional Farwest Show staff executes a strategic marketing and production plan designed to reach horticultural buyers of plants, products and services throughout North America.

2010 SHOW INFORMATION

Dates: August 26-28 (Thursday through Saturday)
Hours: Thursday & Friday- 12:00 noon to 6:00 p.m.
Saturday- 12:00 noon to 4:00 p.m.
Location: Oregon Convention Center, Portland, Oregon
Information: 800-342-6401 or 503-682-5089; Fax 503-682-5099
Web address: www.farwestshow.com

Show Producer: Oregon Association of Nurseries. 29751 SW Town Center Loop W,
Wilsonville, Oregon, 97070.

BOOTH RENTAL INCLUDES

- 10' x 10' exhibit space.
- 8' high backdrop (not included with island booth).
3' side rails of flame retardant material (not included with island booth).
- One-line company identification sign, to include firm name and booth number.
- Fork lift service provided during move-in/out (please note – this service is free with your personal vehicle only. If you use a common carrier service, you will be charged for drayage service by DWA).
- Water/Ice for plant material.
- Name badges for exhibitors.

DECORATOR AND DRAYAGE

The official Farwest Show decorator and drayage company is:

DWA TRADE SHOW & EXPOSITION SERVICES
3721 NW Front Avenue
Portland, Oregon 97210
Ph: 503.228.6800 Fax: 503.595.1470
Email: csr@dwatradeshow.com

All questions regarding rental of equipment, shipment of freight to the show or special services required may be directed to this company.

EXHIBITOR SERVICES

DWA Trade Show & Exposition Services serves as the show decorator and provides exhibitor services beyond those listed above in booth rental. Additional services are provided on a rental basis. Electrical outlets/hook-ups, tables, chairs, booth cleaning or other special arrangements can all be ordered through DWA's exhibitor packet which is distributed to all participating exhibitors. You will be able to order your material from DWA online.

MOVE-IN & MOVE-OUT AGE LIMIT

Heavy equipment and machinery is prevalent on the show floor during move-in and move-out of the Farwest Show, and safety is a major concern of the Oregon Association of Nurseries. **No children under the age of 11 will be allowed on the show floor during move-in and move-out hours, and all children between the ages of 12 and 15 will be required to be accompanied by an adult at all times.** We appreciate the burden this may create for many of our exhibitors who have family-owned businesses, but safety concerns for all individuals on the show floor will require that we strictly enforce this regulation.

MOVE-IN & MOVE-OUT LOGISTICS

The Farwest Show employs a phased move-in, with each exhibitor being assigned a block of time between Tuesday, August 24, and Wednesday, August 25. Each exhibitor will be designated a morning or afternoon move-in pass for their assigned move-in day. Move-in times will be assigned based on size and complexity of the exhibitor's display and location in the exhibit hall. Exhibitors who miss their assigned move-in time will lose their priority for availability to the loading dock and roll-up doors and may experience longer wait times. Exhibitors who will need loading dock space or forklift or pallet jack access will be required to check in at a Marshalling Yard located at DWA Warehouse.

All move-in must be completed by 8:00 p.m. on Wednesday, August 25 if advance notification is not received and approved by the Farwest Show Manager for late arrival. Booths not installed by 8:00 p.m. on Wednesday may be subject to resale.

Move-out will not be permitted until 4 p.m. on closing day. Any exhibitor removing or dismantling exhibit display prior to 4 p.m. on closing day may be denied space in future Farwest Shows. The Farwest attracts a full and diverse audience for the exhibitor and expects to present a full show to all visitors during all scheduled hours of the show. Move-out will continue until 10:00 p.m. on Saturday and from 8:00 a.m. until 3:00 p.m. on Sunday, August 29. Trucks that will need access to the loading dock will be required to check in at the Marshalling Yard. Before entrance to the loading dock is allowed, all material must be palletized and ready to load.

SALE LIMITATIONS

The Farwest Show is a closed industry trade show. Direct, individualized sale of items that are taken from any exhibit booth prior to the close of the show is prohibited. This rule is necessary in order to provide all exhibitors balanced security, and to help ensure against theft of plant material and supplies. Items may be sold directly from the booth but may not be removed from the booth and/or exhibit hall until 4 p.m. on closing day (See Security).

SPACE ASSIGNMENT

Any exhibiting firm occupying booth space in the Farwest Show is given first choice on that location for the subsequent year's show. Exhibitors desiring to upgrade their booth location(s) should contact the Farwest Show office for the Booth Relocation/Expansion Request Form. While upgrading opportunities are limited, preference will be given to those desiring upgraded locations by exhibitor seniority status and in order of receipt.

An exhibit space "Wait List" is maintained by the Farwest Show. Your name will remain on the list until your place in order is reached or you request us to remove your name. Exhibitors can complete the online wait list form at www.farwestshow.com. The "Wait List" for future Farwest Shows will be established in order based on the time that space request is received. The Farwest Show reserves the right to establish a formula for space allocation of "green goods" and "service/supply" exhibitors on the "wait list" in an effort to maintain a balanced show.

Exhibit space is owned solely by the Oregon Association of Nurseries, producer of the Farwest Show, and ownership is non-transferable.

2011 BOOTH PRICES

Exhibitors signing an exhibit contract and paying for booth space for the 2011 Farwest Show will be given a 10% discount if paid IN FULL by cash, check or by Visa / MasterCard prior to the close of the 2010 show. **2011 exhibit space contracts will be available in the show office during the 2010 show.**

PAYMENTS AND BOOTH CANCELLATIONS

The schedule of payments due for the 2010 Farwest Show booth space is as follows:

1. First half of total amount due October 31, 2009.
2. Second half due April 30, 2010.

Booth space of exhibitors failing to make full payment by April 30, 2010, may be considered vacant and subject to re-sale.

Exhibitors that have signed and paid for a booth space under the OAN member benefit rate, but have not renewed their membership for the current year will be invoiced after April 1, 2010 for the non-member booth rate. Payment will be due April 30, 2010.

New exhibitors entering the show after May 1 may make tentative reservations on available space for a period of fourteen (14) days, upon which time payment in full is due for final booth space confirmation.

2010 contracts cancelled prior to October 31, 2009, will be assessed a \$25.00 handling fee; contracts cancelled after October 31, 2009, but prior to April 30, 2010, will be assessed a \$100.00 handling fee; contracts cancelled after April 30, 2010, but prior to July 15, 2010, will be assessed a penalty equal to one-half of the exhibit space fee. **No** refunds will be given for the 2010 exhibit space contracts cancelled after July 15, 2010.

SUB-LEASING

No exhibitor may assign, sublet or apportion the whole or any part of the booth space assigned, nor permit any other party to exhibit therein, nor distribute any promotional or advertising materials in the assigned space other than those manufactured, grown or sold by exhibitor in the normal course of his/her business. Penalty for violation may be loss of exhibit space.

EXHIBITOR SOLICITING

Exhibitors must limit their activities to within the confines of the assigned booth space and conduct themselves in an appropriate manner that does not interfere with legitimate activities of other exhibitors. The distribution of exhibitor's product, catalogs, pamphlets, printed material, souvenirs, etc., must remain within the confined area of the assigned booth space. This means at no time should product or promotional materials protrude, for any distance, into the exhibit hall aisles, or be handed out in the aisle to attendees or other exhibitors. No exhibitor's promotional activities will be permitted outside the confines of assigned exhibit booth, except in such cases as approved by Show Management.

NON-EXHIBITOR SOLICITING

Show Management makes every effort to protect against unauthorized selling within the show exhibit area by individuals not booking space. The Farwest Show requests any individual attempting to sell or market in the aisle, or other areas of the Convention Center, be reported. These individuals are taking advantage of exhibitors who pay for their space and abide by show rules.

CHARACTER OR EXHIBITS

The Farwest Show retains the right to restrict exhibits to products and services of interest to and related to the nursery and horticultural trade. The management also reserves the right to restrict exhibits which, because of noise, method of operation, materials, or for any reason are deemed to be objectionable, and also to prohibit or evict any exhibit which, in the opinion of the management, may detract from the general character of the Farwest Show. This reservation includes persons, things, conduct, printed matter or anything of a character which the management determines objectionable. In the event of such restriction or eviction, the Farwest Show is not liable for any refunds for rentals or other exhibit expense. All exhibits must include a person(s) in their booths at all times, with the exception of minimal breaks. Exhibitors who fail to manage their booth may not be allowed to exhibit in future shows.

DISPLAY CONFIGURATIONS

Exhibit height in excess of three feet must be confined to the rear five feet of each booth. The diagrams on pages 8 & 9 show graphically exactly how this rule is interpreted by the Farwest Show. **The five-foot set-back rule will be enforced.** The Farwest Show will strictly enforce this rule, and any violation must be immediately corrected or loss of booth space may result. No signs, partitions, apparatus, shelving, display material, etc., may extend beyond eight feet above the exhibit space floor. Show management requires a written variance for any portion of your exhibit which extends beyond the eight-foot limit.

Island exhibits do allow for structures to be built up to 12'. In addition, **all ISLAND BOOTHS can have signage as high as 12'**. If the booth faces a series of 10' x 10' booths that are not island booths, then a 3' high restriction is in place for the first 3' of your booth. This requires that you only have materials that allow attendees to "see-through" your display above the 3' to the next exhibit. Booth sides that face another island booth or a wall can utilize the 12' height restriction to the edge of the booth. The diagram shown on page 8 will better demonstrate these regulations as they pertain to the island booths.

A request for a variance from the Farwest Show must be submitted no later than July 31, 2010, and will be approved only in the case where the extended height serves as an integral part of the display. Variances are not required for plant material that extends beyond eight feet in the back of the exhibit space. However, exhibitors may not use plant material which adversely impacts a neighboring exhibitor. Show Management reserves the right of final decision in determining the importance of the display material exceeding standard show rules and regulations.

SPECIAL EQUIPMENT REQUIREMENTS

The operation of oil, alcohol or gasoline engines is prohibited during show hours and all such **engines must be free of all such fuels and fuel tank caps must be taped closed while on display in the exhibit area.** In addition, **all battery cables must be disconnected** during exhibition of vehicles and cable ends must be taped to meet fire department regulations.

Audio-visual equipment is limited in its operation to sales demonstrations only and shall not be used for showings designed to attract or entertain visitors. All audio visual equipment shall be in accordance with the requirements of the fire prevention authorities and in harmony with any agreements entered into by the Farwest Show, the Oregon Convention Center and applicable labor unions. **The use of loud speakers and public address equipment by exhibitors is absolutely prohibited.** Exhibits which include the operation of musical instruments, radios or any noise-making equipment must be conducted or arranged so that the noise resulting from the demonstrations will not disturb adjacent exhibitors. All plans for installation and operation of special sound equipment must be approved by the Farwest Show prior to installation.

The Farwest Show does not have a performing rights license issued by ASCAP, thus, the performance or use of copyrighted music, whether live, tapes, CDs, videos, etc., is prohibited. Exhibitors are responsible for any action taken by ASCAP or other such organization. Failure to observe this rule may be grounds for removal from the Show.

HAZARDOUS MATERIALS

No exhibitor will be allowed to bring any hazardous material into the exhibit hall for any purpose during hours of move-in, show hours or move-out. The Farwest Show requires the use of empty display containers that have never been filled with hazardous materials. This rule will be strictly enforced. Hazardous materials are defined as follows:

1. Any material packaged in a container that has the words "danger", "warning" or "poison" on it, accompanied by a phrase such as, but not limited to, "do not get on skin," "do not get in eyes," "do not breathe dust;"
2. Live aerosol spray cans.

Rules and regulations set forth by the Portland Fire Bureau covering hazardous materials must be followed, or exhibits are subject to removal from the show.

PETS

Except for guide dogs, no animals or pets are permitted in exhibit hall or booths at any time without Show Management approval, who in turn, must get approval from the facility. It is also forbidden to house animals in automobiles or trucks parked on Convention Center property.

SECURITY

The Farwest Show will attempt to provide adequate security service for the exhibit area during show hours as well as when the show is closed. As further protection, the Farwest Show encourages each exhibitor to have at least one employee in the booth during move-in and move-out hours. The ultimate responsibility of security lies with the exhibitor at all times and the Farwest Show shall not be held liable for the loss or theft of any or all items from an exhibit booth at any time.

Exhibitors are encouraged to secure and insure valuable items, including but not limited to televisions, computers, small equipment and tools. It is strongly suggested to remove such items immediately upon the close of the show. Please note, during move-in and move-out hours it is impossible to assure total protection of exhibits and items within them. Exhibitors can assist the Farwest Show by securing items of value during these hours.

EXHIBITORS CREDENTIALS

In keeping with our efforts to provide exhibitors and show visitors with the best possible security, it is important that all exhibitors and guests wear, in clear view at all times, the appropriate name badges. Non-exhibitors will not be permitted in the exhibit halls other than during posted show hours. Exhibitors found distributing "exhibitor" passes to show guests may be denied exhibit space in future shows. Exhibitor badges are for exhibitors, show management and staff only; associates, clients and family members of exhibitors will be provided credentials upon request, but these should be designated other than "exhibitor." Remember, rules covering registration and security are for the protection and benefit of Farwest Show exhibitors.

NON-COMPLIANCE TO RULES AND REGULATIONS

Each exhibitor, for himself/herself and his employees, substitutes or agents, agrees to abide by the rules and regulations given herein and by subsequent amendments and additions, considered by the Farwest Show to be in the best interest of all exhibitors. Upon non-compliance with the established rules, the Farwest Show reserves the right to prohibit, reject or eject any exhibitor, exhibitor's representative, exhibit (in whole or part) or visitor, with or without giving cause. In the event of restriction or eviction, the Farwest Show is not liable for any refunds on rentals or other exhibit expenses.

AMENDMENTS TO RULES

These rules, regulations and conditions and the exhibitor's space agreements have been drawn for the purpose and intention of providing a well-balanced, regulated, attractive and successful

exposition. Any and all matters, or questions not specifically covered by the preceding rules and regulations or the Exhibit Space Contract, shall be subject solely to the decision of the Farwest Show. The Farwest Show shall have full power to so interpret the rules and regulations, or make such judgments, as may appear to be for the best interests of the Farwest Show and the Oregon Association of Nurseries, and any and all amendments of the foregoing rules, regulations and conditions shall bind the exhibitors.

LIMITATION OF LIABILITY

It is expressly understood and agreed, and the exhibitor agrees by accepting these rules and regulations, and by signing the Exhibit Space Contract, that he/she will make no claim of any kind against the Farwest Show, the Oregon Association of Nurseries, its members, employees or agents for any loss, damage or destruction of goods, nor for any injury or death that may occur to himself or his employees, associates, aides or guests while on the show grounds, nor for any damage of any nature or character whatsoever.

Rules and regulations contained above are considered to be in addition to rules and regulations printed on the Farwest Show Exhibit Space Contract. Signing of the exhibitor's contract accepts the conditions and limits listed above.

Farwest Display Booth Dimensions

Diagram 1 - Single Unit

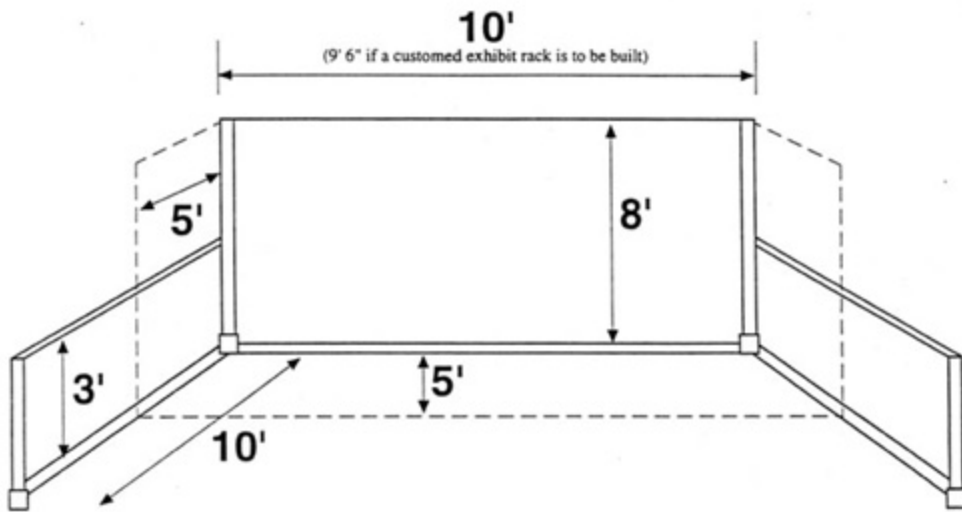
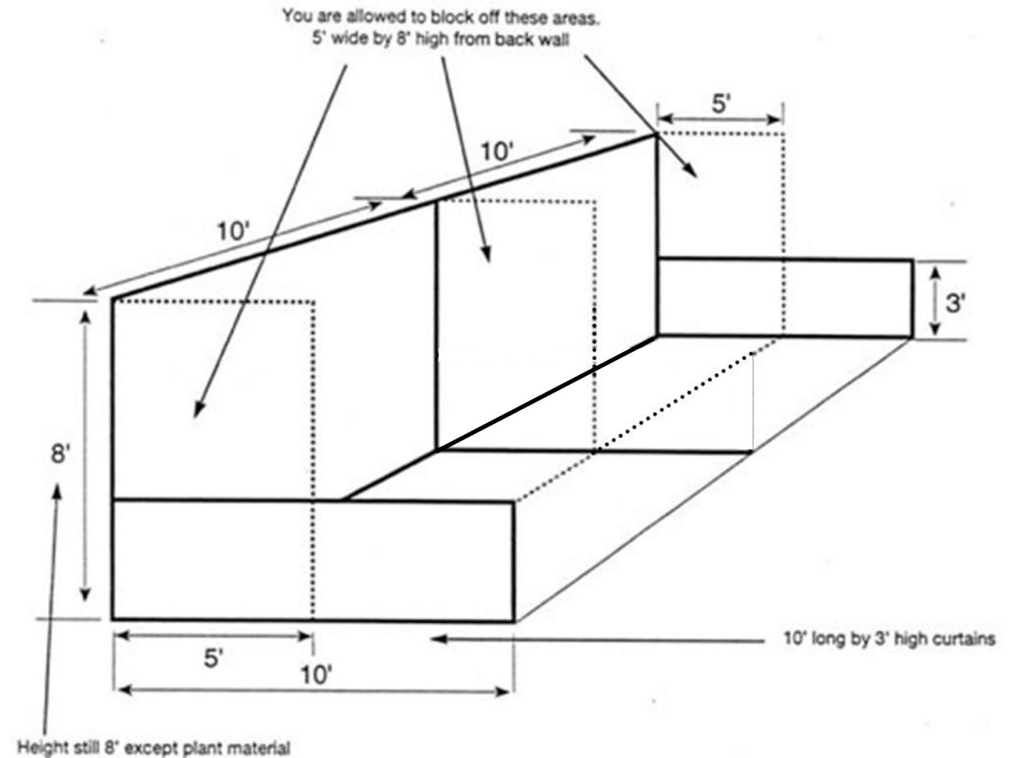

Diagram 2 - Multiple Units



BOOTH DESIGN: In order to ensure a positive experience for all exhibitors, there are specific limitations regarding the set up of your booth. So that you do not block your neighbor, the following rules will be enforced:

Each single booth space is 10'x10', includes an 8-foot high backdrop and 3-foot high side curtains that separate you from your neighbor. Within this space, your height restrictions are:

- From the aisle, the first 5-feet is limited to 3-feet in height for solid, display materials. Items exceeding 3-feet must allow attendees to see through your booth to the next exhibit space. This includes plant material.
- From the middle 5-foot mark of your booth toward the backdrop, you may have solid material up to 8-feet in height. Plant material may exceed this. Signage may not.
- If you are building a customized exhibit rack, please note that the side curtains take up 3 inches on each side and that your building width should be 9'6". Otherwise, it may not fit into your booth space.

Island Booth Diagram

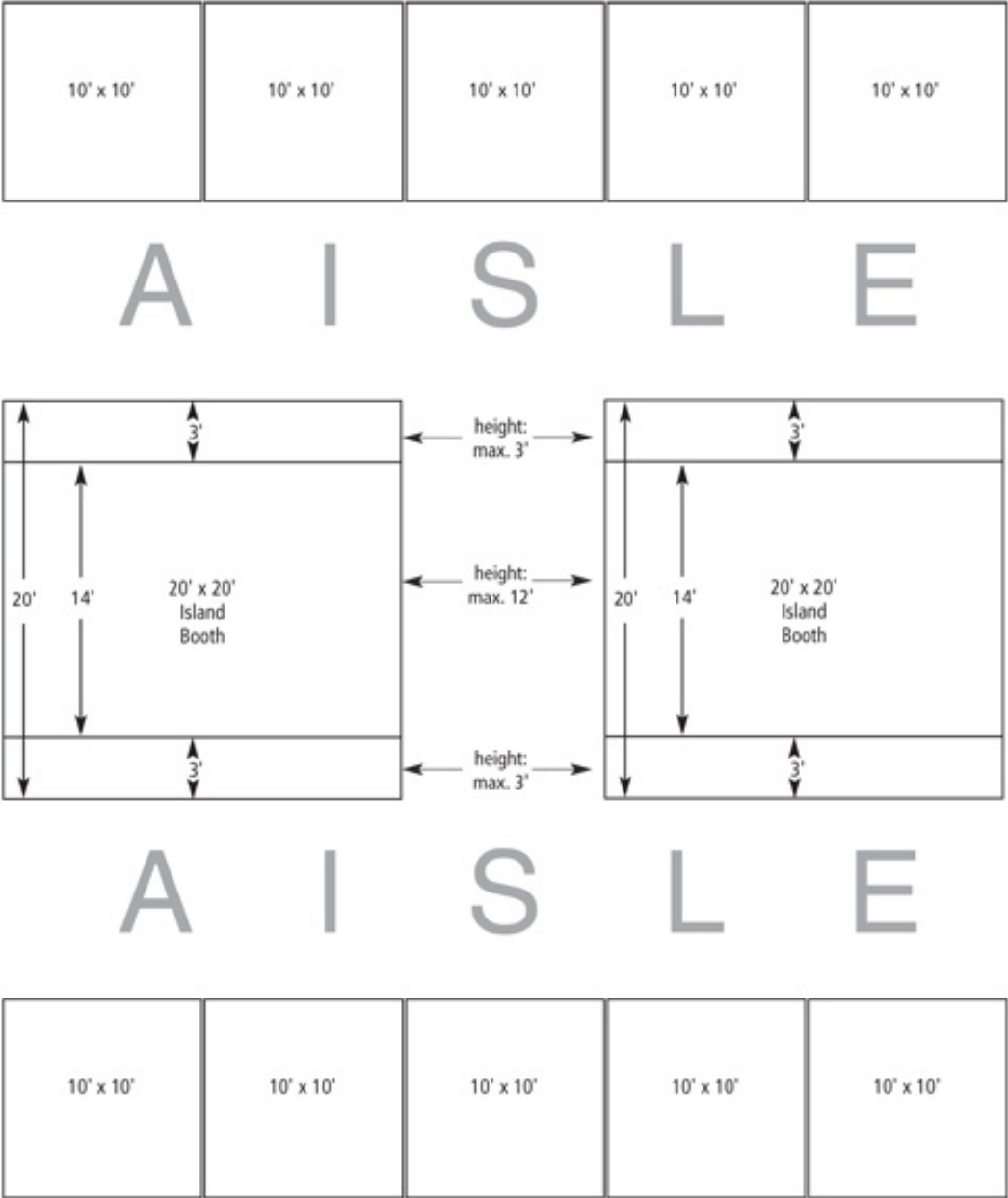

Each Island space is 20'x20' and does not include pipe and drape. In order to be a good neighbor, the following height restrictions will be enforced:

- Where the island faces a series of 10'x10' booth spaces, the first 3-feet is limited to 3-feet in height for solid, display materials. Items exceeding 3-feet must allow attendees to see through your booths to the next exhibit space. This includes plant material.
- Where the island faces a neighboring island space or wall, the 12-foot height restriction may be utilized up to the edge of the booth.

End Cap Diagram

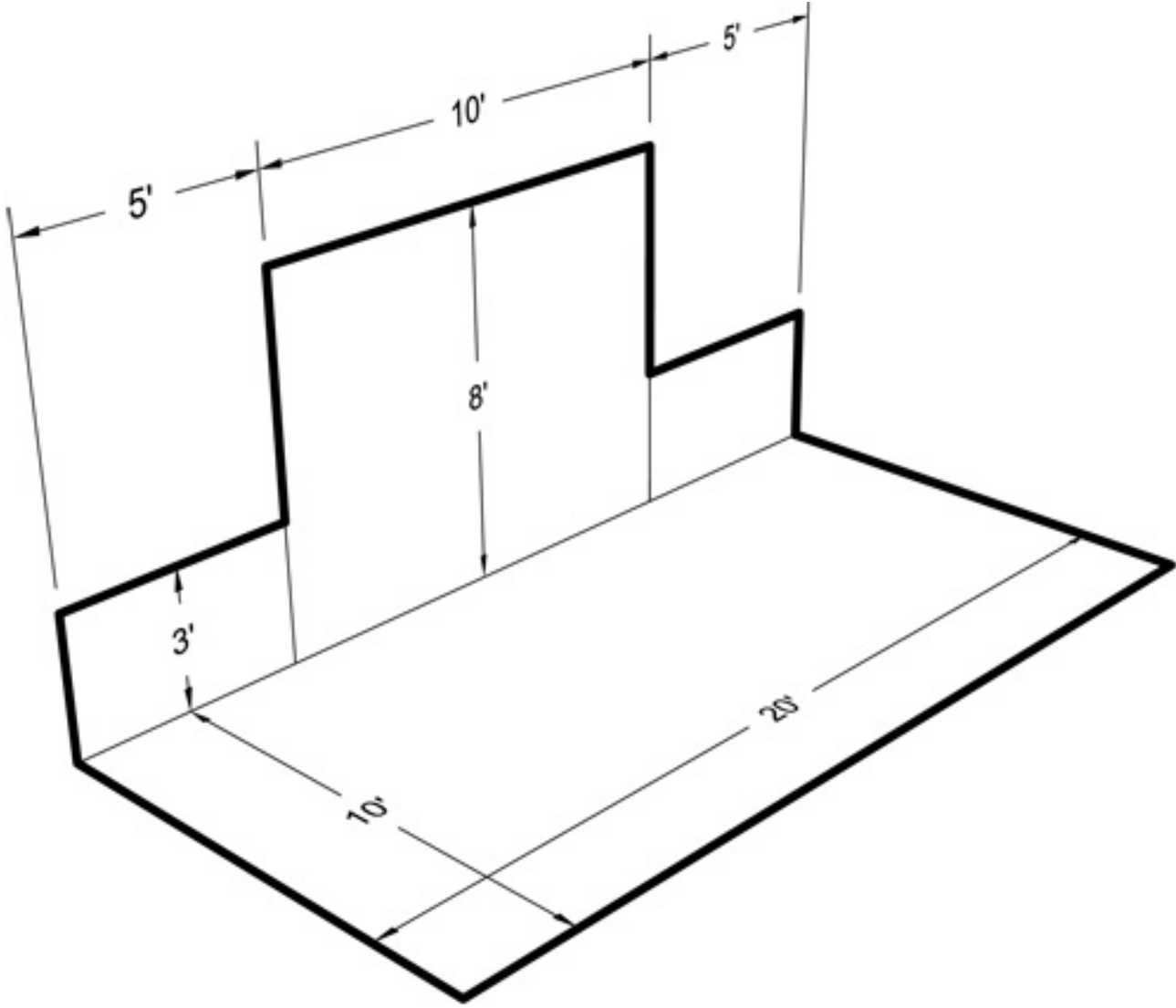

An end cap booth space is 10'x20', includes a 10-foot wide, 8-foot high backdrop bookended by 5-foot wide, 3-foot high back curtains that separate you from neighbors located behind you. Within this space, your height restrictions are:

- From the front aisle, the first 5-feet is limited to 3-feet in height for solid, display materials. Items exceeding 3-feet must allow attendees to see through your booths to the next exhibit space. This includes plant material.
- From the middle 5-foot mark of your booth toward the backdrop, you may have solid material up to 8-feet in height within the 10-foot wide backdrop. Plant material may exceed this. Signage may not.
- From each side aisle, along the 3-foot high back curtains, display materials are limited to 3-foot high. Items exceeding 3-feet must allow attendees to see through your booth to the exhibit space behind you. This includes plant material.